

REVISIONS			
REV	DESCRIPTION	DATE	APPROVED
--	--	--	--

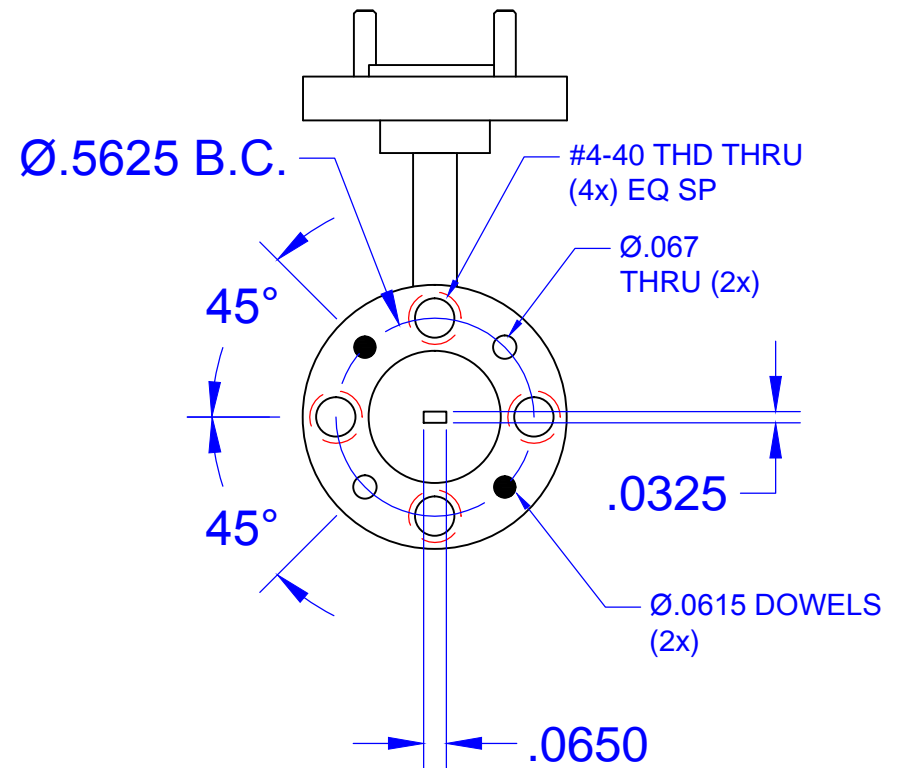
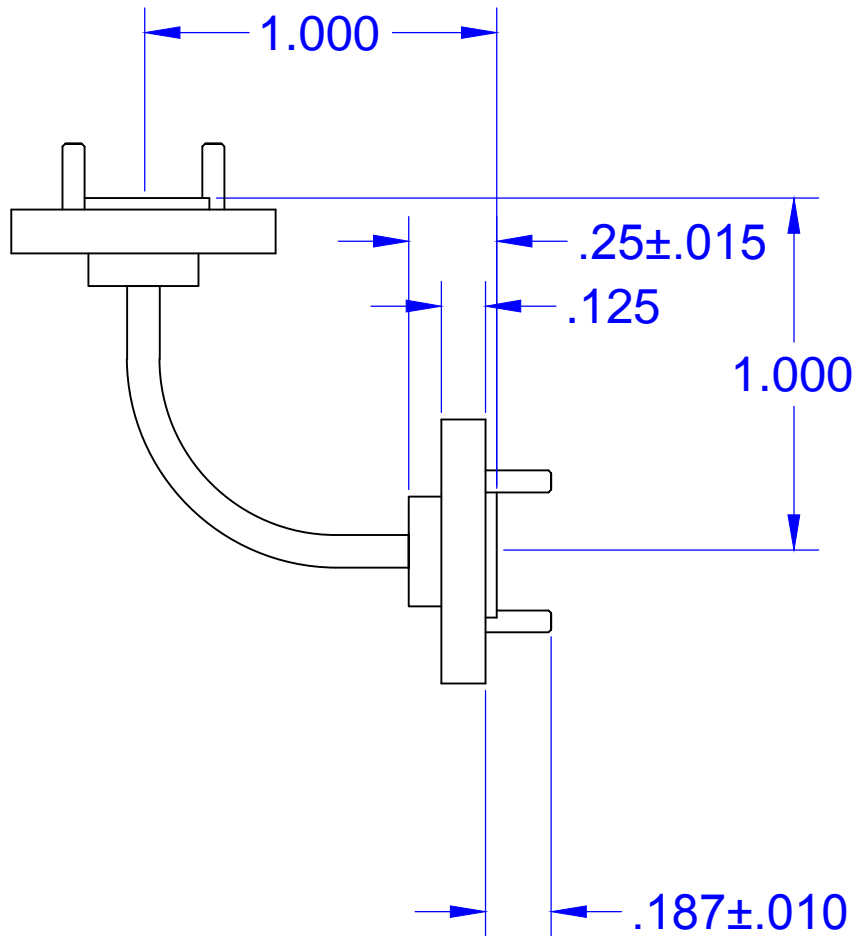
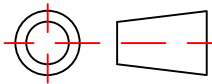

UNLESS OTHERWISE SPECIFIED ALL SURFACES $\sqrt{32}$	 THIRD ANGLE PROJECTION	Mi-Wave Millimeter Products Inc.	
		TITLE 660D/387 E PLANE BEND OUTLINE	
DIMENSIONS ARE IN INCHES TOLERANCES ARE: DECIMALS: .1234 +/- .0005 .123 +/- .005 .12 +/- .01 ANGLES: +/- .5 DEGREES	DRAFTING: K.S.	APPROVED: M.S.	
ALL THREADS TO BE 2A OR 2B	DATE: 6/10/2010		
REF DWG# --	SHEET NO. 1	OF 1	SIZE A
ORIGINAL DWG# 20164	DWG NO 24849		